

Document ID# 1706926
2006 Chevrolet Corvette

Crankcase Ventilation Hoses/Pipes Replacement (PCV Dirty Air Tube)

Removal Procedure

1. Remove the engine sight shield covers. Refer to [Upper Intake Manifold Sight Shield Replacement](#).

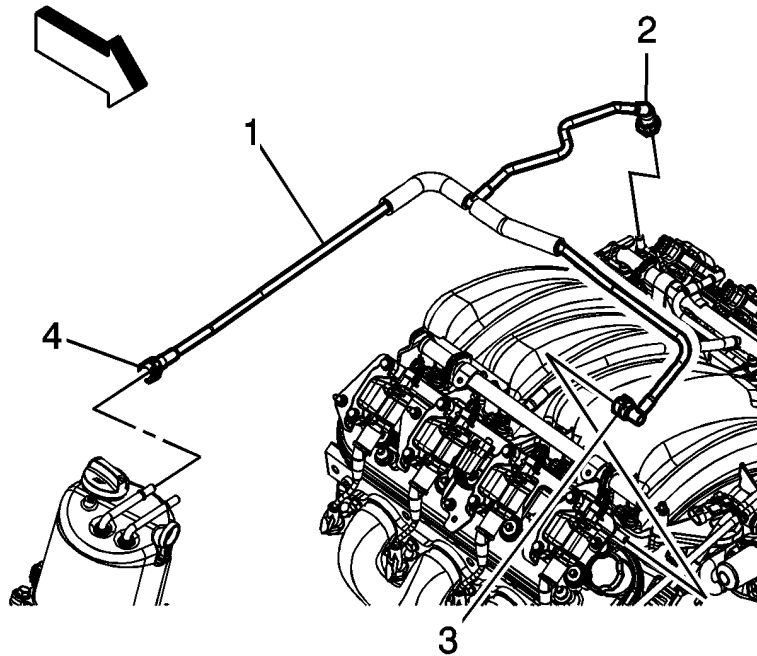

Important: Prior to removal, mark the PCV tube quick disconnect fittings at the oil supply tank or they can be incorrectly installed.

2. Disconnect the PCV tube quick disconnect fitting (4) from the rear port on the oil tank.
3. Disconnect the PCV tube quick disconnect fitting (3) from the port on the RH front valve cover.
4. Disconnect the PCV tube quick disconnect fitting (2) from the port on the LH rear valve cover.

5. Remove the PCV dirty air tube (1).

Installation Procedure

1. Position the PCV dirty air tube (1).

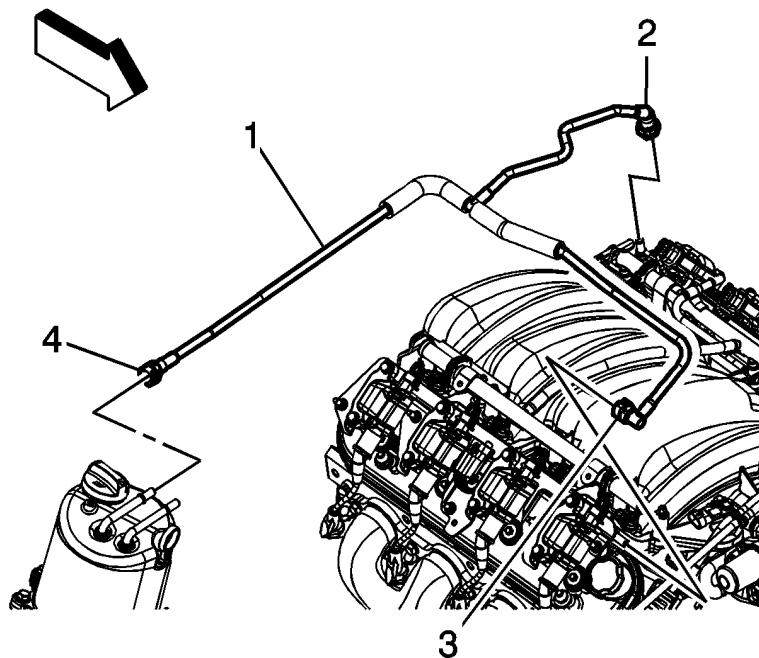

2. Connect the PCV tube quick disconnect fitting (2) to the port on the LH rear valve cover.
3. Connect the PCV tube quick disconnect fitting (3) to the port on the RH front valve cover.
4. Connect the PCV tube quick disconnect fitting (4) to the rear port on the oil tank.
5. Install the engine sight shield covers. Refer to [Upper Intake Manifold Sight Shield Replacement](#) .

Document ID# 1706926
2006 Chevrolet Corvette